



STATE LAW REQUIRES SEPARATE IRRIGATION METERS (General Statutes 143-355.4)

State law requires a separate irrigation meter for all new in-ground irrigation systems connected to the public water supply. The intent of this legislation is to reduce water systems vulnerability to drought and allow them a quicker response to water shortages. Residential customers needing a $\frac{3}{4}$ " or larger irrigation service now have two options:

OPTION 1: SINGLE SERVICE LINE

For new construction with irrigation, one 1" line will be tapped onto the main, and two meters will be set from the reduced $\frac{3}{4}$ " line. The full connection charge will be collected for the domestic service and the irrigation service, with a reduced tap charge.

On an existing domestic service adding irrigation, a tee will be installed just before the domestic meter on the domestic line.

Backflow prevention assembly is typically installed immediately following the meter.

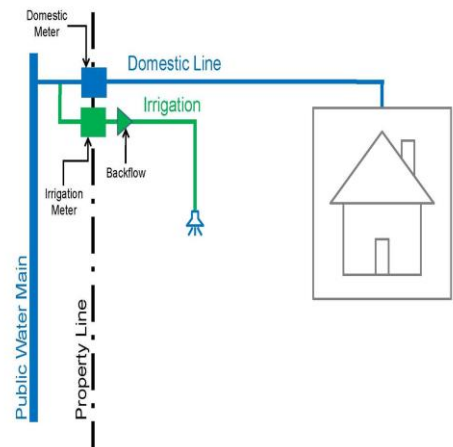

OPTION 2: DEDICATED SERVICE LINE

The customer can elect to have a separate tap and a separate line run to each meter box. In this case, the standard connection charges and tap fees will be assessed. This option may be necessary if the existing domestic meter is in a driveway or there is some other circumstance that prevents splitting off the single service line.

If customers need more than a $\frac{3}{4}$ " irrigation service, they may purchase larger services for added capacity.

Services larger than $\frac{3}{4}$ " will be tapped on the main with standard connection and tap fees.

Backflow prevention device is typically installed immediately following the meter.

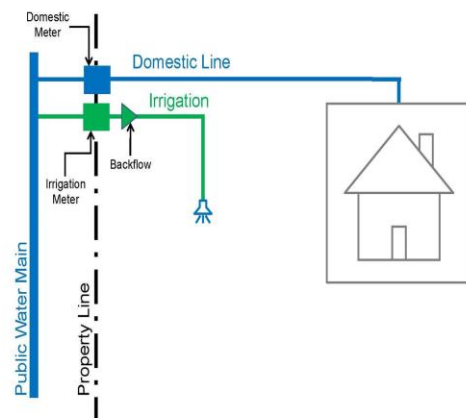

BACKFLOW PROTECTION

To ensure the safety of our community's drinking water, a backflow prevention assembly is required on in-ground irrigation systems. This prevents hazardous substances from inadvertently being drawn into the drinking water system, contaminating it.

The private water service connection (section of pipe between the meter and the backflow preventer including an isolation valve and the backflow preventer itself) serving the irrigation system must be installed by a North Carolina licensed plumbing or utility contractor. Workmanship and materials for this part of the system must be permitted and inspected by Pender County Utilities.

Inspections of the private water service connection must be requested and scheduled by the contractor.

IRRIGATION CONTRACTORS

Installations of new in-ground irrigation systems costing \$2,500 or more must be performed by a North Carolina licensed irrigation contractor, unless the work is done by the property owner. Exclusions include agricultural and nursery operations. Visit www.nciclb.org for more details. Water meter box must be at or above existing grade upon inspection to pass; bottom of meter shall be level with bottom of box. If below box, service must be raised and centered in box.

Pender County Utilities Irrigation Supply Connection

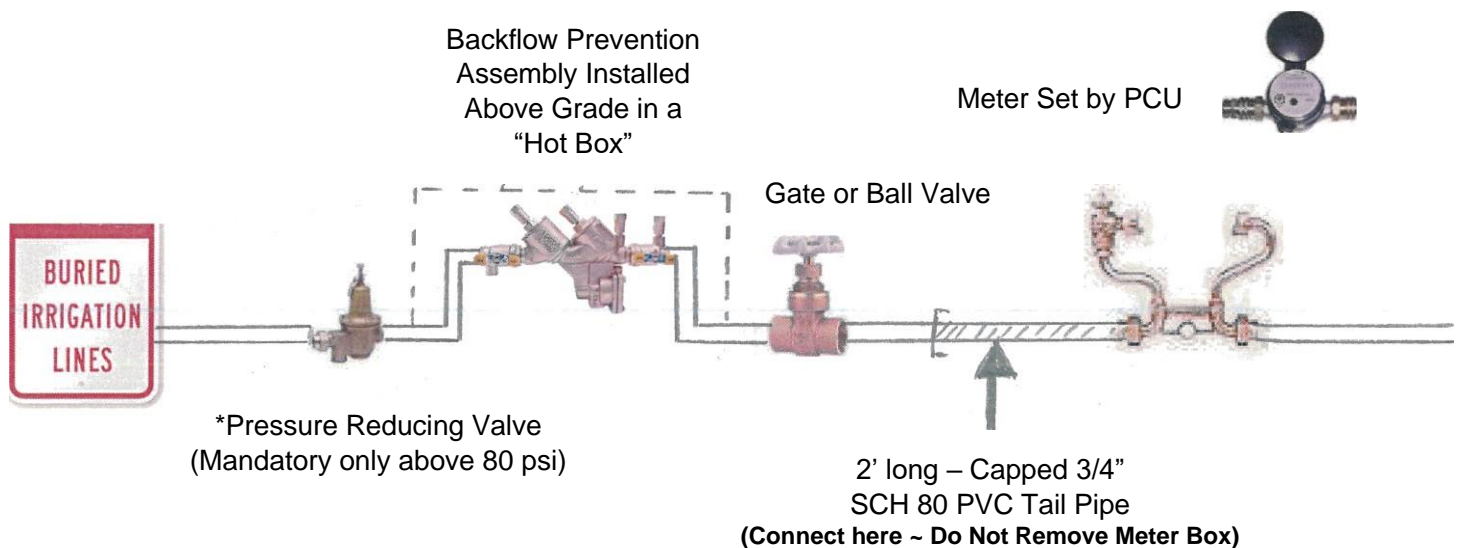

MORE INFORMATION

To request an irrigation meter or for meter and fee questions, call 910-259-1570.